

Trench drain body with integral galvanized rails - 39.40" (1000mm) length

Channel body FILCOTEN® pro – V 200 (8") – heavy duty series

	Body part number		Overall body depth			Maximum flow rate			Weight (less grate)	
	galv. rails	Channel type	Slope	E1 (Min.)	E2 (Max.)	GPM *)	LPS *)	CFS *)	Lbs	Kg
○	10620200	200/0	0 %	10.43" (265 mm)	10.43" (265 mm)	369.3	23.3	0.82	97.00	44.0
○	10620261	200/5-0	0 %	11.42" (290 mm)	11.42" (290 mm)	439.1	27.7	0.98	108.69	49.3
○	10620262	200/10-0	0 %	12.40" (315 mm)	12.40" (315 mm)	515.1	32.5	1.15	119.71	54.3
○	10620264	200/20-0	0 %	14.37" (365 mm)	14.37" (365 mm)	678.4	42.8	1.51	138.23	62.7
○	10620201	200/1	0.5 %	10.43" (265 mm)	10.63" (270 mm)				98.11	44.5
○	10620202	200/2	0.5 %	10.63" (270 mm)	10.83" (275 mm)				100.31	45.5
○	10620203	200/3	0.5 %	10.83" (275 mm)	11.02" (280 mm)				102.51	46.5
○	10620204	200/4	0.5 %	11.02" (280 mm)	11.22" (285 mm)				104.94	45.6
○	10620205	200/5	0.5 %	11.22" (285 mm)	11.42" (290 mm)				107.14	48.6
○	10620206	200/6	0.5 %	11.42" (290 mm)	11.61" (295 mm)				109.57	49.7
○	10620207	200/7	0.5 %	11.61" (295 mm)	11.81" (300 mm)				111.77	50.7
○	10620208	200/8	0.5 %	11.81" (300 mm)	12.01" (305 mm)				114.20	51.8
○	10620209	2100/9	0.5 %	12.01" (305 mm)	12.20" (310 mm)				116.40	52.8
○	10620210	200/10	0.5 %	12.20" (310 mm)	12.40" (315 mm)				118.83	53.9

*) GPM = Gallons per minute, LPS = Liters per second, CFS = Cubic feet per second

Specification: FILCOTEN pro-V NW200, 9.37" (238mm) wide, 39.40" (1000mm) long, pre-sloped (0.5%) or neutral FILCOTEN trench drain system. Body is manufactured from a fibre-reinforced concrete based material. Bodies have interlocking ends, a radiused extract for efficient liquid drainage and a multiple anchoring ribs to securely hold the body into the concrete foundation. Each body is manufactured with an integral 0.16" (4mm) thick, extra heavy duty, galvanized steel rail. End and bottom outlets are available in 8" (200mm) no hub outlet connections. Grate options include extra heavy duty ductile iron (Load Class D and E), slotted and perforated heavy duty galvanized steel (Load Class B, C and D). Grates are secured to the body with a four point self-locking system. End caps and catch basins are also available.

Function: Used in commercial areas such as factories, warehouses, parking garages, car dealerships, gas stations, public and residential areas, parks, sports complexes, town squares, railway stations and cycle and foot paths. Ideal for environmentally sensitive areas because the body channels are free of resins, heavy metals, VOC and chemicals. Exceptional adhesion to surrounding concrete foundation due to the concrete composition of the body channels - resulting in a monolithic all concrete installation. Less breakage during transport and installation due to impact resistant, fibre-reinforced, UV resistant concrete material. Extra heavy duty integral galvanized steel rail allows for heavy duty, hard wheel traffic applications.

1. Channel:

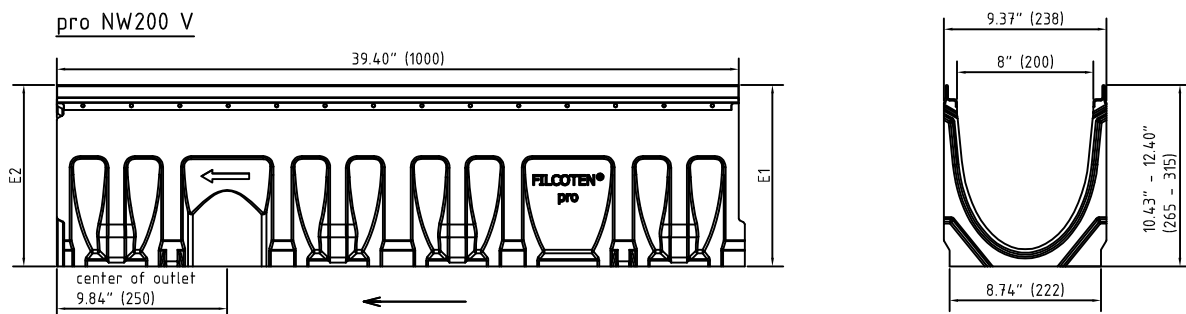

MATERIALS: Channels shall be manufactured from Filcoten fiber composite with concrete edge cast galvanized rail. Minimum properties of Filcoten fiber composite will be as follows:

Compressive strength:	11700 PSI
Flexural strength:	1700 PSI
Free of release agents:	YES
Water absorption sufficient for adhesion with concrete surfaces:	YES

Non flammable:	YES
U/V resistant:	YES
Recyclable 100%:	YES
Dilute acid and alkali resistant:	YES
Frost thaw salt tested as per EN1433 with a test temperature up to -40°C (-40°F):	YES
Material free of VOC, biocides, heavy metals:	YES